

RELION® 611 SERIES

Motor Protection and Control

REM611

Product Guide



Contents

1. Description.....	3	15. Station communication.....	11
2. Standardized configuration.....	3	16. Technical data.....	16
3. Protection functions.....	6	17. Local HMI.....	32
4. Application.....	7	18. Mounting methods.....	32
5. Supported ABB solutions.....	8	19. Relay case and plug-in unit.....	33
6. Control.....	9	20. Selection and ordering data.....	34
7. Measurement.....	9	21. Accessories and ordering data.....	35
8. Disturbance recorder.....	9	22. Tools.....	35
9. Event log.....	10	23. Cyber security.....	36
10. Recorded data.....	10	24. Terminal diagram.....	37
11. Trip circuit supervision	10	25. Certificates.....	37
12. Self-supervision.....	10	26. References.....	37
13. Access control.....	10	27. Functions, codes and symbols.....	38
14. Inputs and outputs.....	10	28. Document revision history.....	39

Disclaimer

The information in this document is subject to change without notice and should not be construed as a commitment by ABB. ABB assumes no responsibility for any errors that may appear in this document.

© Copyright 2019 ABB.

All rights reserved.

Trademarks

ABB and Relion are registered trademarks of the ABB Group. All other brand or product names mentioned in this document may be trademarks or registered trademarks of their respective holders.

1. Description

REM611 is a dedicated motor protection relay for the protection, control, measurement and supervision of asynchronous motors in manufacturing and process industry. Typically, the relay is used with circuit breaker or contactor-controlled medium-sized or small motors in a variety of drives, such as pumps and conveyors, crushers and choppers, mixers and agitators, and fans and aerators.

REM611 is a member of ABB's Relion® product family and part of the 611 protection and control product series. The 611 series relays are characterized by their compactness and withdrawable-unit design.

The 611 series offers simplified yet powerful functionality for most applications. Once the application-specific parameter set has been entered, the installed protection relay is ready to be put into service. The further addition of communication functionality and interoperability between substation automation devices offered by the IEC 61850 standard adds flexibility and value to end users as well as electrical system manufacturers.

The 611 series relays fully support the IEC 61850 standard for communication and interoperability of substation automation devices, including fast GOOSE (Generic Object Oriented Substation Event) messaging, and can now also benefit from the extended interoperability provided by Edition 2 of the standard. The relays further support the parallel redundancy protocol (PRP) and the high-availability seamless redundancy (HSR) protocol. The 611 series relays are able to use IEC 61850 and Modbus® communication protocols simultaneously.

2. Standardized configuration

REM611 is available in one configuration.

To increase the user-friendliness of the configuration and to emphasize the simplicity of usage of the relay, only the application-specific parameters need setting within the relay's intended area of application.

The standard signal configuration can be altered by local HMI, Web HMI or optional application functionality of Protection and Control IED Manager PCM600.

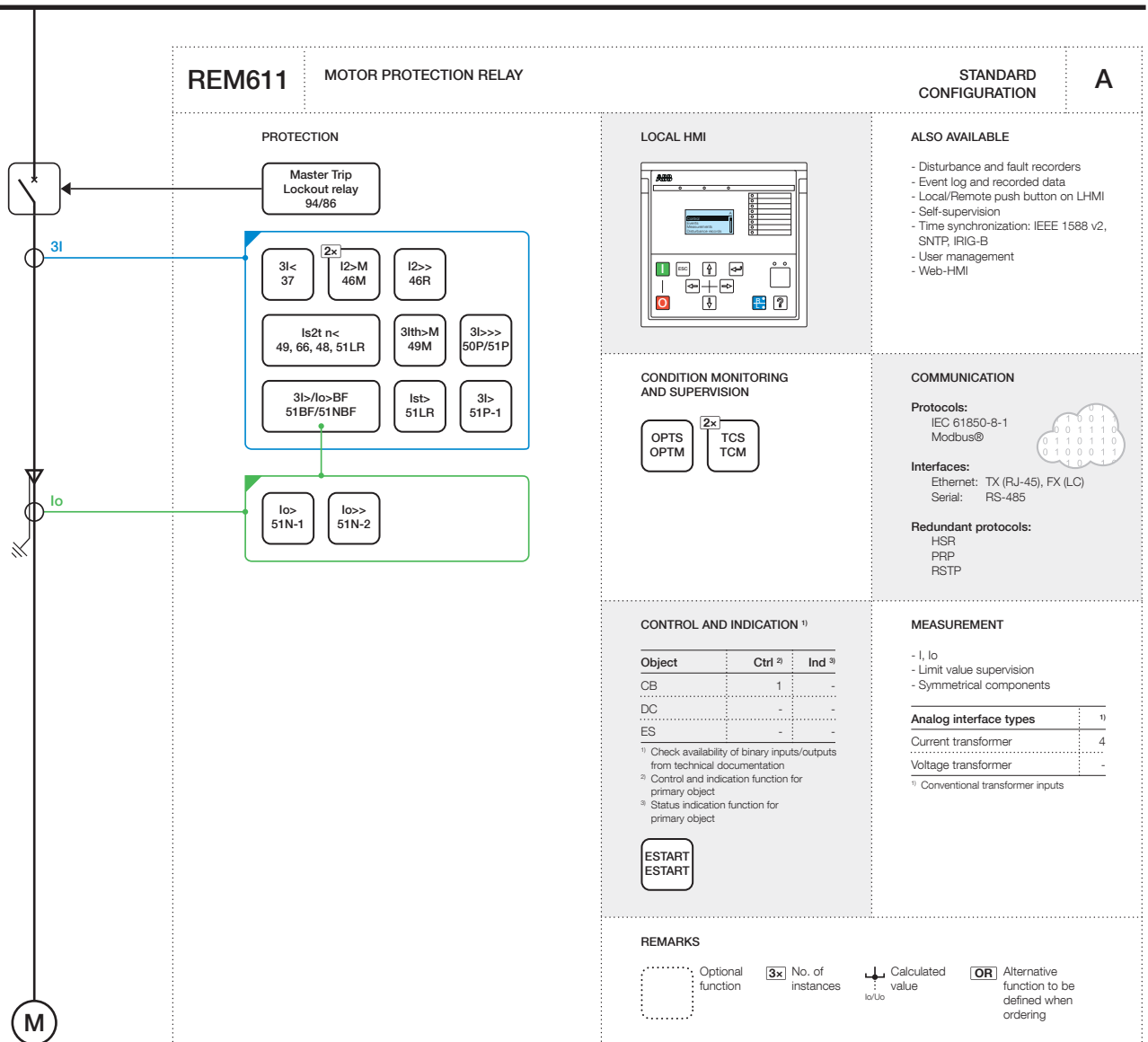

Figure 1. Functionality overview for configuration A

Table 1. Standardized configuration

Description	Conf.
Motor protection	A

Table 2. Supported functions

Function	IEC 61850	A
Protection		
Three-phase non-directional overcurrent protection, low stage	PHLPTOC	1
Three-phase non-directional overcurrent protection, instantaneous stage	PHIPTOC	1
Non-directional earth-fault protection, low stage	EFLPTOC	1 ¹⁾
Non-directional earth-fault protection, high stage	EFHPTOC	1 ¹⁾
Negative-sequence overcurrent protection for machines	MNSPTOC	2
Loss of load supervision	LOFLPTUC	1
Motor load jam protection	JAMPTOC	1
Motor start-up supervision	STTPMSU	1
Phase reversal protection	PREVPTOC	1
Thermal overload protection for motors	MPTTR	1
Circuit breaker failure protection	CCBRBRF	1
Master trip	TRPPTRC	1
Control		
Circuit-breaker control	CBXCBR	1
Emergency start-up	ESMGAPC	1
Condition monitoring and supervision		
Trip circuit supervision	TCSSCBR	2
Runtime counter for machines and devices	MDSOPT	1
Logging		
Disturbance recorder	RDRE	1
Fault recorder	FLTRFRFC	1
Measurement		
Three-phase current measurement	CMMXU	1
Sequence current measurement	CSMSQI	1
Residual current measurement	RESCMMXU	1
Other		
Input switch group	ISWGAPC	10
Output switch group	OSWGAPC	20
Selector	SELGAPC	6
Minimum pulse timer (2 pcs)	TPGAPC	10
Minimum pulse timer (2 pcs, second resolution)	TPSGAPC	1
Move (8 pcs)	MVGAPC	1

1, 2, ... = Number of included instances. The instances of a protection function represent the number of identical protection function blocks available in the standardized configuration.

() = optional

1) Io selectable by parameter and default value is "Io measured"

3. Protection functions

REM611 offers all functionalities needed to manage motor starts and normal operation, including protection and fault clearance in abnormal situations. The relay includes thermal overload protection, motor start-up time supervision, locked rotor protection and protection against too frequent motor starts. The relay also incorporates non-directional earth-fault, negative phase-sequence current unbalance and backup overcurrent protection. Further, the relay offers stall protection, loss-of-load supervision and phase-reversal protection.

Certain motor drives require a possibility to override the motor thermal overload protection to perform an emergency start of a hot motor. To enable the emergency hot start, the relay offers a forced start execution feature.

4. Application

REM611 constitutes the main protection for asynchronous motors and the associated drives. Typically, the relay is used with circuit-breaker or contactor-controlled medium or small sized motors in a variety of drives, such as pumps and conveyors, crushers and choppers, mixers and agitators, and fans and aerators.

using a cable current transformer. Phase current transformers in Holmgreen (summation) connection can also be used for earth-fault protection. In that case, possible unwanted operations of the earth-fault protection at motor start-up, due to current transformer saturation, can be prevented using the relay's internal interlocking features or a suitable stabilizing resistor in the common neutral return.

The relay is thoroughly adapted for earth-fault protection. Sensitive and reliable earth-fault protection can be achieved

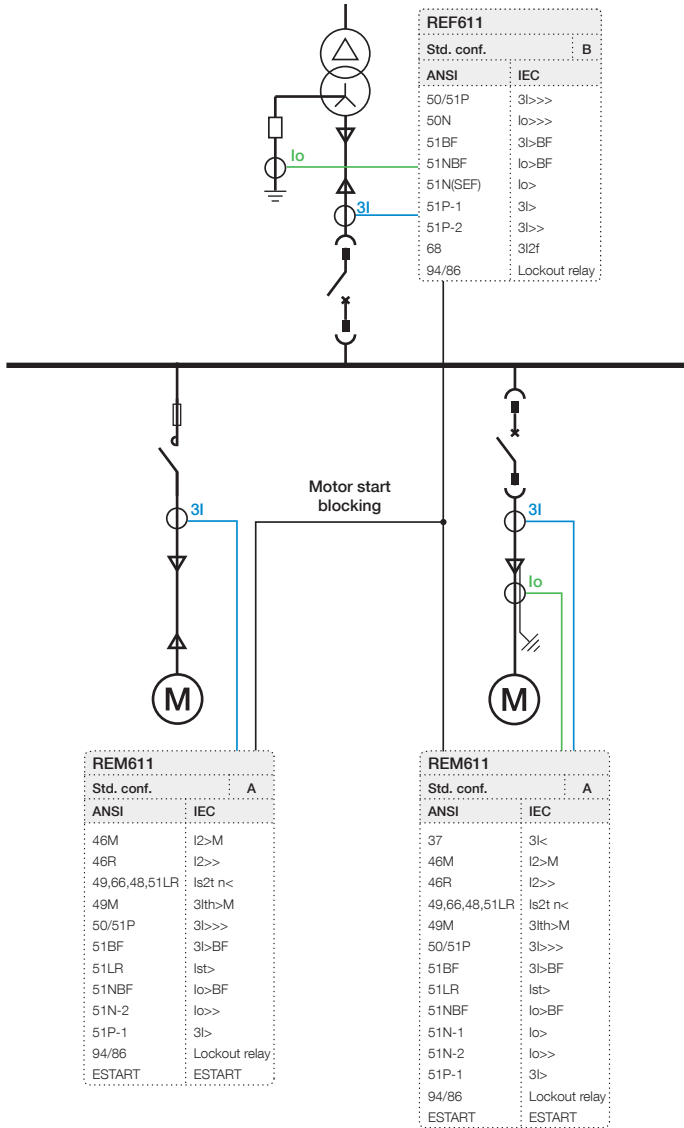

Figure 2. Motor protection and control of contactor and circuit-breaker controlled motors based on configuration A

Figure 4 shows an example of motor protection and control of contactor and circuit-breaker controlled motors based on configuration A. The motor start-up signal is used to

dynamically increase the setting level of the lowest overcurrent protection stage of REF611 on the incoming feeder.

5. Supported ABB solutions

The 611 series protection relays together with the Substation Management Unit COM600S constitute a genuine IEC 61850 solution for reliable power distribution in utility and industrial power systems. To facilitate the system engineering, ABB's relays are supplied with connectivity packages. The connectivity packages include a compilation of software and relay-specific information and a full relay data model. The data model includes event and parameter lists. With the connectivity packages, the relays can be readily configured using PCM600 and integrated with COM600S or the network control and management system MicroSCADA Pro.

The 611 series relays offer native support for the IEC 61850 standard, including limited binary GOOSE messaging. Compared to traditional hard-wired, inter-device signaling, peer-to-peer communication over a switched Ethernet LAN offers an advanced and versatile platform for power system protection. The implementation of the IEC 61850 substation automation standard enables access to distinctive features including fast software-based communication, continuous supervision of the protection and communication system's integrity, and inherent flexibility for reconfiguration and upgrades.

At substation level, COM600S uses the data content of the bay-level devices to enhance substation level functionality.

COM600S features a Web browser-based HMI, which provides a customizable graphical display for visualizing single-line mimic diagrams for switchgear bay solutions. The Web HMI of COM600S also provides an overview of the whole substation, including relay-specific single-line diagrams, which makes information easily accessible. Substation devices and processes can also be remotely accessed through the Web HMI, which improves personnel safety.

In addition, COM600S can be used as a local data warehouse for the substation's technical documentation and for the network data collected by the devices. The collected network data facilitates extensive reporting and analyzing of network fault situations by using the data historian and event handling features of COM600S. The historical data can be used for accurate monitoring of process and equipment performance, using calculations based on both real-time and historical values. A better understanding of the process dynamics is achieved by combining time-based process measurements with production and maintenance events.

COM600S can also function as a gateway and provide seamless connectivity between the substation devices and network-level control and management systems, such as MicroSCADA Pro and System 800xA.

Table 3. Supported ABB solutions

Product	Version
Substation Management Unit COM600S	4.0 SP1 or later
	4.1 or later (Edition 2)
MicroSCADA Pro SYS 600	9.3 FP2 or later
	9.4 or later (Edition 2)
System 800xA	5.1 or later

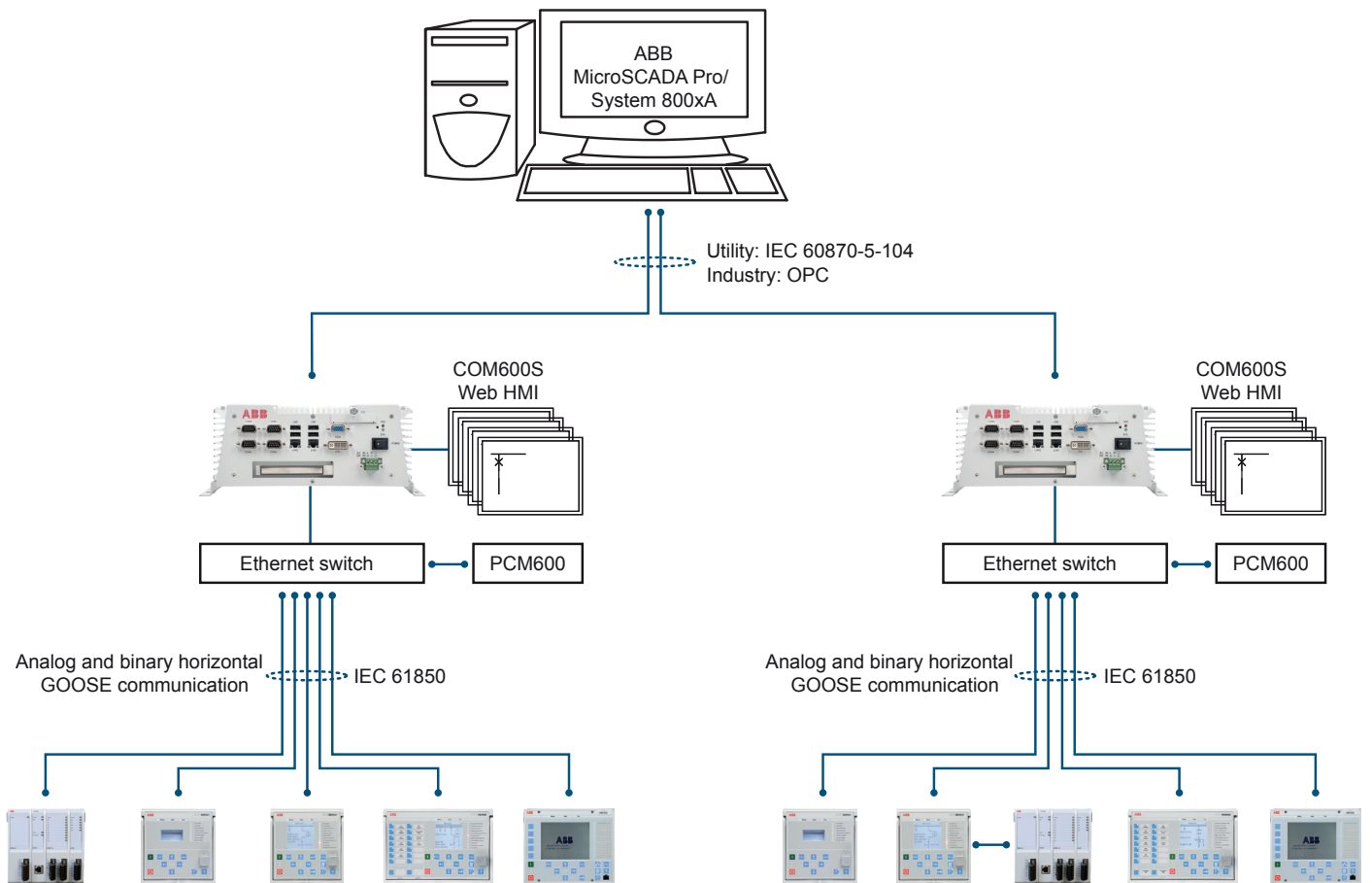

Figure 3. ABB power system example using Relion relays, COM600S and MicroSCADA Pro/System 800xA

6. Control

The relay offers control of one circuit breaker or contactor with dedicated push buttons for opening and closing via the local HMI or a remote system, for example, PCM600.

By default, the relay is equipped with a single input interlocking scheme. Binary GOOSE messaging can be used in the creation of additional interlocking schemes, such as secured object control (SOC), blocking-based protection schemes or external tripping.

These additional protection and control schemes required by specific applications are configured using the local HMI, the Web HMI and the optional application functionality of PCM600. The local HMI and the Web HMI can be utilized for signal configuration, while PCM600 is required for the configuration of GOOSE messaging.

7. Measurement

The relay continuously measures phase currents and neutral current.

In addition, the relay calculates the symmetrical components of the currents and the maximum current demand value over a user-selectable preset time frame.

The measured values can be accessed via the local HMI or remotely via the communication interface of the relay. The values can also be accessed locally or remotely using the Web HMI.

8. Disturbance recorder

The relay is provided with a disturbance recorder featuring preconfigured analog and binary channels. The analog channels can be set to record either the waveform or the trend of the currents and voltages measured.

The analog channels can be set to trigger the recording function when the measured value falls below or exceeds the set values.

The binary signal channels can be set to start a recording either on the rising or the falling edge of the binary signal or on both.

By default, the binary channels are set to record external or internal relay signals, for example, the start or trip signals of the relay stages, or external blocking or control signals. Binary relay signals, such as protection start and trip signals, or an external relay control signal via a binary input, can be set to trigger the recording. Recorded information is stored in a nonvolatile memory and can be uploaded for subsequent fault analysis.

9. Event log

To collect sequence-of-events information, the relay has a nonvolatile memory capable of storing 1024 events with the associated time stamps. The nonvolatile memory retains its data even if the relay temporarily loses its auxiliary supply. The event log facilitates detailed pre- and post-fault analyses of feeder faults and disturbances. The considerable capacity to process and store data and events in the relay facilitates meeting the growing information demand of future network configurations.

The sequence-of-events information can be accessed either via local HMI or remotely via the communication interface of the relay. The information can also be accessed locally or remotely using the Web HMI.

10. Recorded data

The relay has the capacity to store the records of the 128 latest fault events. The records enable the user to analyze the most recent power system events.

Each record includes current and angle values, start times of the protection blocks, time stamp, and so on.

The fault recording can be triggered by the start signal or the trip signal of a protection block, or by both.

The available measurement modes include DFT, RMS and peak-to-peak. In addition, the maximum demand current with time stamp is recorded separately. By default, the records are stored in the non-volatile memory of the device.

11. Trip circuit supervision

The trip circuit supervision continuously monitors the availability and operation of the trip circuit. It provides two open-circuit

monitoring functions that can be used to monitor the circuit breaker's control signal circuits. It also detects loss of circuit-breaker control voltage.

12. Self-supervision

The relay's built-in self-supervision system continuously monitors the state of the relay hardware and the operation of the relay software. Any fault or malfunction detected is used for alerting the operator.

A permanent relay fault blocks the protection functions to prevent incorrect operation.

13. Access control

To protect the relay from unauthorized access and to maintain information integrity, the relay is provided with a four-level, role-based authentication system with administrator-programmable individual passwords for the viewer, operator, engineer and administrator levels. The access control applies to the local HMI, the Web HMI and PCM600.

14. Inputs and outputs

The relay is equipped with three phase-current inputs and one residual-current input. The phase-current inputs and the residual current input are rated 1/5 A, that is, the inputs can be connected to either 1 A or 5 A secondary current transformers. The optional residual current input of 0.2/1 A is normally used in applications requiring sensitive earth-fault protection and featuring core-balance current transformers.

The rated currents of the analog inputs can be selected in the relay software. In addition, the binary input threshold (16...176 V DC) can be selected by adjusting the relay's parameter settings.

All binary input and output contacts are preconfigured according to the configuration, but can be easily reconfigured by setting application-based parameters using the signal configuration functionality of the local HMI and Web HMI.

See the input and output overview table and the terminal diagram for more information about the inputs and outputs.

Table 4. Input/output overview

Conf.	Analog channels		Binary channels	
	CT	VT	BI	BO
A	4	-	4	6

15. Station communication

The 611 series protection relays support the IEC 61850 and Modbus® communication protocols. Operational information and controls are available through these protocols. However, some communication functionality, for example, horizontal communication between the protection relays, is enabled only by the IEC 61850 communication protocol.

The IEC 61850 protocol is a core part of the relay as the protection and control application is fully based on standard modelling. The relay supports Edition 1 and Edition 2 versions of the standard. With Edition 2 support, the relay has the latest functionality modelling for substation applications and the best interoperability for modern substations. It incorporates also full support for standard device mode functionality supporting different test applications. Control applications can utilize the new safe and advanced station control authority feature.

The IEC 61850 communication implementation supports monitoring and control functions. Additionally, parameter settings, disturbance recordings and fault records can be accessed using the IEC 61850 protocol. Disturbance recordings are available to any Ethernet-based application in the standard COMTRADE file format. The relay supports simultaneous event reporting to five different clients on the station bus. The relay can exchange data with other devices using the IEC 61850 protocol.

The relay can send binary and analog signals to other devices using the IEC 61850-8-1 GOOSE (Generic Object Oriented Substation Event) profile. Binary GOOSE messaging can be employed, for example, for protection and interlocking-based protection schemes. The relay meets the GOOSE performance

requirements for tripping applications in distribution substations, as defined by the IEC 61850 standard (<10 ms data exchange between the devices).

For redundant Ethernet communication, the relay offers two galvanic Ethernet network interfaces. A third port with galvanic Ethernet network interface is also available providing connectivity for any other Ethernet device to an IEC 61850 station bus inside a switchgear bay, for example connection of a remote I/O. Ethernet network redundancy can be achieved using the high-availability seamless redundancy protocol (HSR) or the parallel redundancy protocol (PRP) or with a self-healing ring using Rapid Spanning Tree Protocol (RSTP) in managed switches. Ethernet redundancy can be applied to Ethernet-based IEC 61850 and Modbus protocols.

The IEC 61850 standard specifies network redundancy which improves the system availability for substation communication. The network redundancy is based on two complementary protocols defined in the IEC 62439-3 standard: PRP and HSR protocols. Both the protocols are able to overcome a failure of a link or switch with a zero switch-over time. In both the protocols, each network node has two identical Ethernet ports dedicated for one network connection. The protocols rely on the duplication of all transmitted information and provide a zero switch-over time if the links or switches fail, thus fulfilling all the stringent real-time requirements of substation automation.

In PRP, each network node is attached to two independent networks operated in parallel, thus providing zero time recovery and continuous checking of redundancy to avoid failures. The networks are completely separated to ensure failure independence, and can have different topologies.

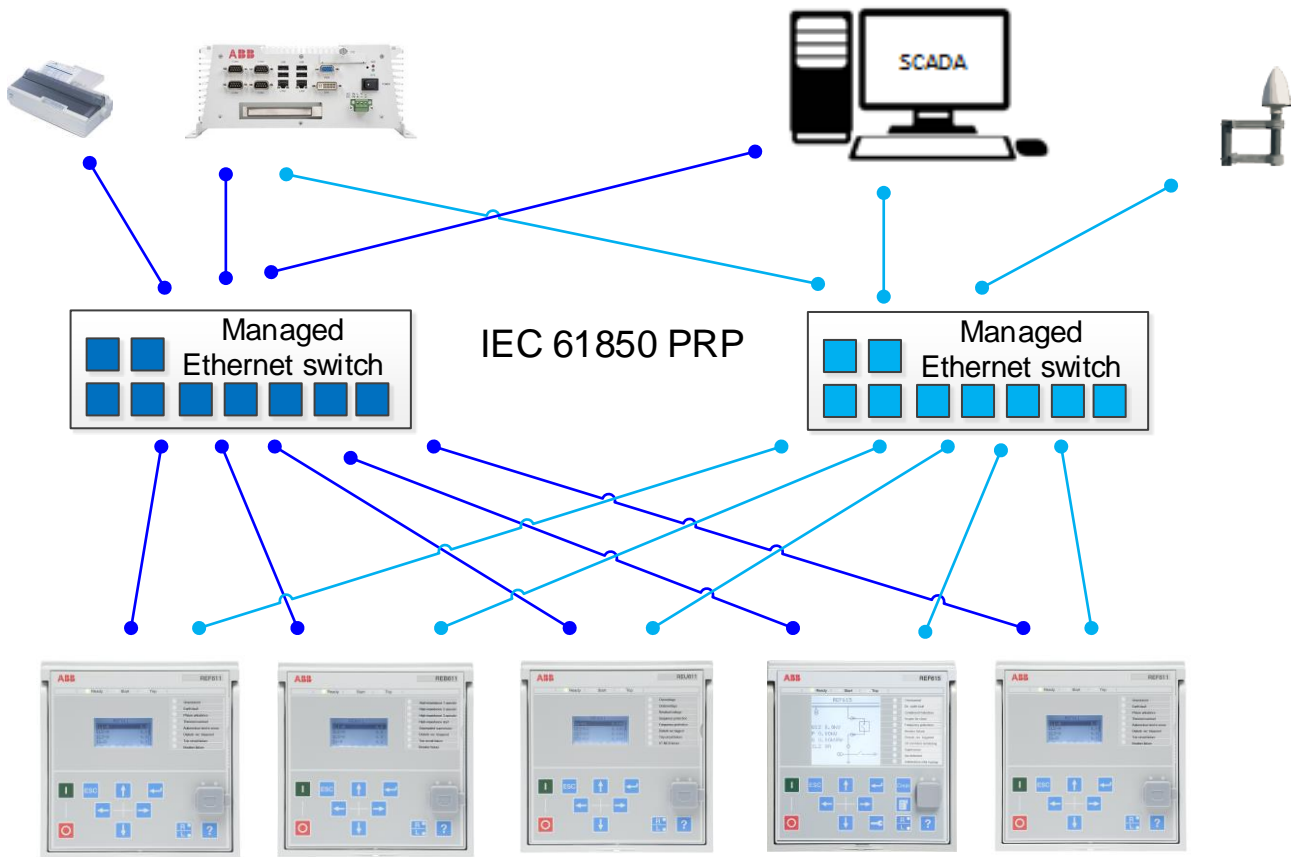

Figure 4. Parallel redundancy protocol (PRP) solution

HSR applies the PRP principle of parallel operation to a single ring. For each message sent, the node sends two frames, one through each port. Both the frames circulate in opposite directions over the ring. Every node forwards the frames it receives from one port to another to reach the next node. When the originating sender node receives the frame it sent, it

discards the frame to avoid loops. The HSR ring with the 611 series relays supports the connection of up to 30 relays. If more than 30 relays are to be connected, it is recommended to split the network into several rings to guarantee the performance for real-time applications.

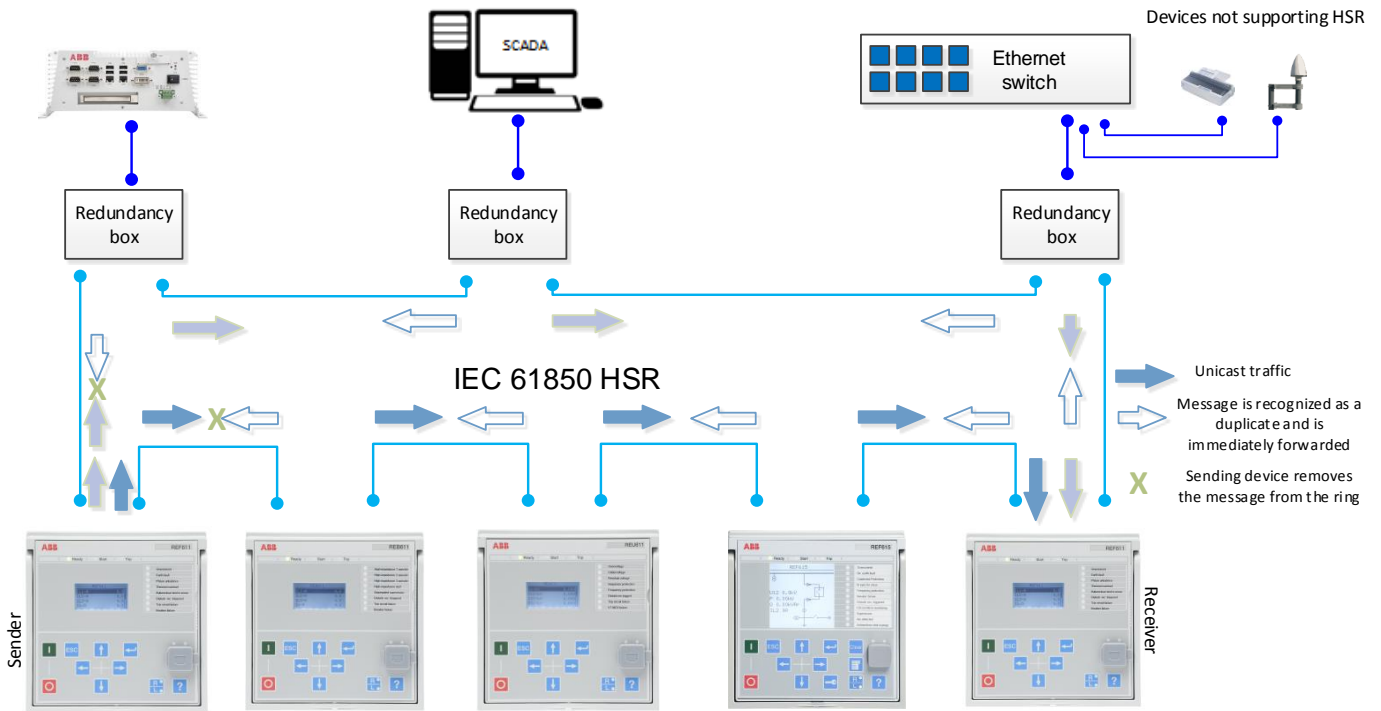

Figure 5. High availability seamless redundancy (HSR) solution

The choice between the HSR and PRP redundancy protocols depends on the required functionality, cost and complexity.

The self-healing Ethernet ring solution enables a cost-efficient communication ring controlled by a managed switch with standard RSTP support. The managed switch controls the consistency of the loop, routes the data and corrects the data

flow in case of a communication switch-over. The relays in the ring topology act as unmanaged switches forwarding unrelated data traffic. The Ethernet ring solution supports the connection of up to 30 relays. If more than 30 relays are to be connected, it is recommended to split the network into several rings. The self-healing Ethernet ring solution prevents single point of failure concerns and improves the reliability of the communication.

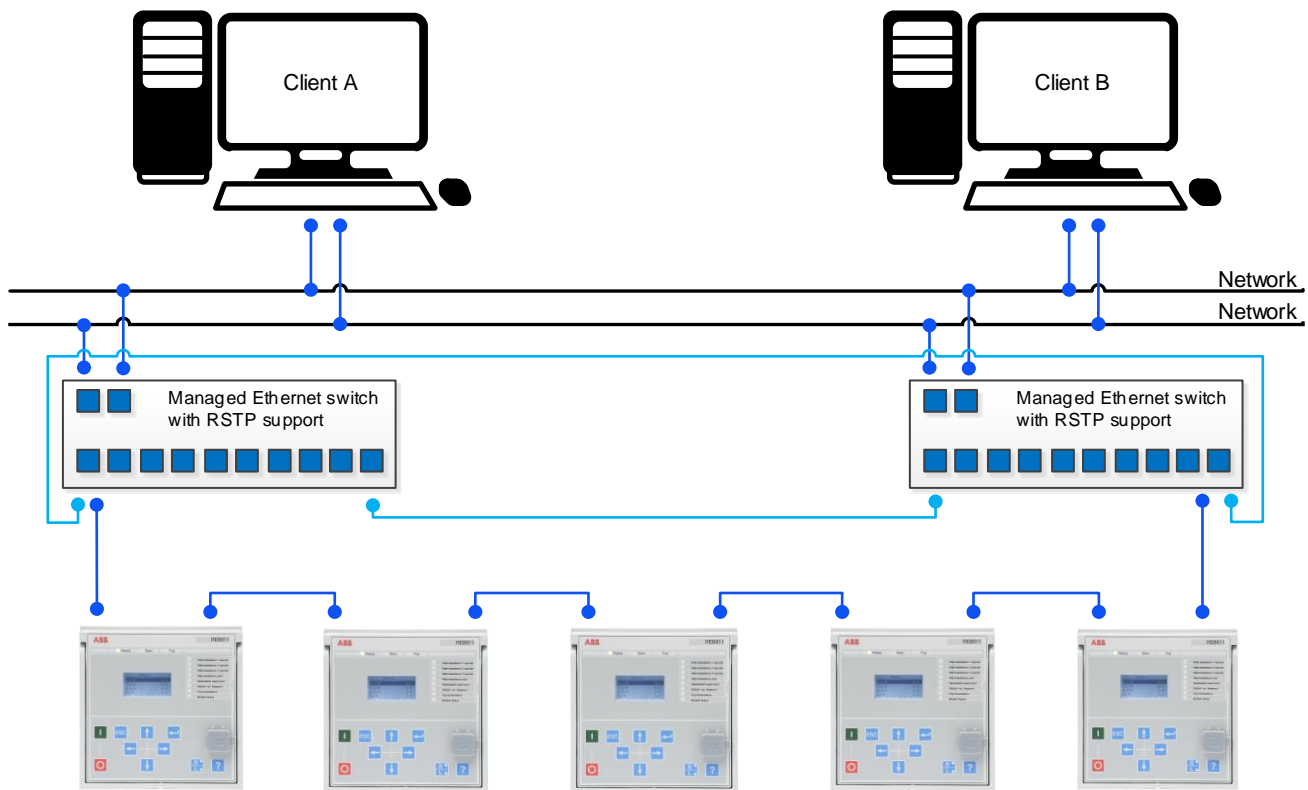

Figure 6. Self-healing Ethernet solution

All communication connectors, except for the front port connector, are placed on integrated optional communication modules. The relay can be connected to Ethernet-based communication systems via the RJ-45 connector (100Base-TX).

The Modbus implementation supports RTU, ASCII and TCP modes. Besides the standard Modbus functionality, the relay supports retrieval of time-stamped events, changing of the active setting group and uploading of the latest fault records. If a Modbus TCP connection is used, five clients can be connected to the relay simultaneously. Further, Modbus serial and Modbus TCP can be used in parallel and, if required, both IEC 61850 and Modbus protocols can be run simultaneously.

When the relay uses the RS-485 bus for the serial communication, both 2-wire and 4-wire connections are supported. Termination and pull-up/down resistors can be configured with jumpers on the communication card so external resistors are not needed.

The relay supports several time synchronization methods with a time-stamping resolution of 1 ms. SNTP can be used in Ethernet based time synchronization and IRIG-B is available with special time synchronization wiring.

For high accuracy time synchronization, the relay supports IEEE 1588 v2 with a time-stamping resolution of 4 μ s.

- Ordinary Clock with Best Master Clock algorithm
- One-step Transparent Clock for Ethernet ring topology
- 1588 v2 Power Profile
- Receive (slave): 1-step/2-step
- Transmit (master): 1-step
- Layer 2 mapping
- Peer to peer delay calculation
- Multicast operation

The required accuracy of grandmaster clock is $\pm 1 \mu$ s. The relay can work as a master clock per the BMC algorithm if the external grandmaster clock is not available for short term.

The IEEE 1588 support is included in all variants having a redundant Ethernet communication module.

In addition, the relay supports time synchronization via Modbus serial communication protocol.

Motor Protection and Control	1MRS757469 G
REM611	
Product version: 2.0	

Table 5. Supported station communication interfaces and protocols

Interfaces/protocols	Ethernet		Serial
	100BASE-TX RJ-45	100BASE-FX LC	RS-485
IEC 61850	•	•	-
MODBUS RTU/ASCII	-	-	•
MODBUS TCP/IP	•	•	-

• = Supported

16. Technical data

Table 6. Dimensions

Description	Value	
Width	Frame	177 mm
	Case	164 mm
Height	Frame	177 mm (4U)
	Case	160 mm
Depth	201 mm (153 + 48 mm)	
Weight	Complete protection relay	4.1 kg
	Plug-in unit only	2.1 kg

Table 7. Power supply

Description	Type 1	Type 2
Nominal auxiliary voltage U_n	100, 110, 120, 220, 240 V AC, 50 and 60 Hz	24, 30, 48, 60 V DC
	48, 60, 110, 125, 220, 250 V DC	
Maximum interruption time in the auxiliary DC voltage without resetting the relay	50 ms at U_n	
Auxiliary voltage variation	38...110% of U_n (38...264 V AC)	50...120% of U_n (12...72 V DC)
	80...120% of U_n (38.4...300 V DC)	
Start-up threshold	19.2 V DC (24 V DC × 80%)	
Burden of auxiliary voltage supply under quiescent (P_q)/operating condition	DC <12.5 W (nominal)/<15.0 W (max.) AC <13.5 W (nominal)/<16.0 W (max.)	DC <10.2 W (nominal)/<10.8 W (max.)
Ripple in the DC auxiliary voltage	Max 15% of the DC value (at frequency of 100 Hz)	
Fuse type	T4A/250 V	

Table 8. Energizing inputs

Description	Value			
Rated frequency	50/60 Hz			
Current inputs	Rated current, I_n	0.2/1 A ¹⁾	1/5 A ²⁾	
	Thermal withstand capability:	• Continuously	4 A	20 A
		• For 1 s	100 A	500 A
		Dynamic current withstand:	• Half-wave value	250 A
	Input impedance		<100 mΩ	<20 mΩ

1) Ordering option for residual current input

2) Residual current and/or phase current

REM611

Product version: 2.0

Table 9. Binary inputs

Description	Value
Operating range	±20% of the rated voltage
Rated voltage	24...250 V DC
Current drain	1.6...1.9 mA
Power consumption	31.0...570.0 mW
Threshold voltage	16...176 V DC
Reaction time	<3 ms

Table 10. Signal output X100: SO1

Description	Value
Rated voltage	250 V AC/DC
Continuous contact carry	5 A
Make and carry for 3.0 s	15 A
Make and carry for 0.5 s	30 A
Breaking capacity when the control-circuit time constant L/R<40 ms, at 48/110/220 V DC	1 A/0.25 A/0.15 A
Minimum contact load	100 mA at 24 V AC/DC

Table 11. Signal outputs and IRF output

Description	Value
Rated voltage	250 V AC/DC
Continuous contact carry	5 A
Make and carry for 3.0 s	10 A
Make and carry 0.5 s	15 A
Breaking capacity when the control-circuit time constant L/R<40 ms, at 48/110/220 V DC	1 A/0.25 A/0.15 A
Minimum contact load	10 mA at 5 V AC/DC

Table 12. Double-pole power output relays with TCS function

Description	Value
Rated voltage	250 V AC/DC
Continuous contact carry	8 A
Make and carry for 3.0 s	15 A
Make and carry for 0.5 s	30 A
Breaking capacity when the control-circuit time constant L/R<40 ms, at 48/110/220 V DC (two contacts connected in series)	5 A/3 A/1 A
Minimum contact load	100 mA at 24 V AC/DC
Trip-circuit supervision (TCS):	
• Control voltage range	20...250 V AC/DC
• Current drain through the supervision circuit	~1.5 mA
• Minimum voltage over the TCS contact	20 V AC/DC (15...20 V)

Table 13. Single-pole power output relays

Description	Value
Rated voltage	250 V AC/DC
Continuous contact carry	8 A
Make and carry for 3.0 s	15 A
Make and carry for 0.5 s	30 A
Breaking capacity when the control-circuit time constant $L/R < 40$ ms, at 48/110/220 V DC	5 A/3 A/1 A
Minimum contact load	100 mA at 24 V AC/DC

Table 14. Front port Ethernet interfaces

Ethernet interface	Protocol	Cable	Data transfer rate
Front	TCP/IP protocol	Standard Ethernet CAT 5 cable with RJ-45 connector	10 Mbits/s

Table 15. Station communication link, fiber optic

Connector	Fiber type ¹⁾	Wave length	Typical max. length ²⁾	Permitted path attenuation ³⁾
LC	MM 62.5/125 or 50/125 μ m glass fiber core	1300 nm	2 km	<8 dB

1) (MM) multi-mode fiber, (SM) single-mode fiber

2) Maximum length depends on the cable attenuation and quality, the amount of splices and connectors in the path.

3) Maximum allowed attenuation caused by connectors and cable together

Table 16. IRIG-B

Description	Value
IRIG time code format	B004, B005 ¹⁾
Isolation	500V 1 min
Modulation	Unmodulated
Logic level	5 V TTL
Current consumption	<4 mA
Power consumption	<20 mW

1) According to the 200-04 IRIG standard

Table 17. Degree of protection of flush-mounted protection relay

Description	Value
Front side	IP 54
Rear side, connection terminals	IP 20

Table 18. Environmental conditions

Description	Value
Operating temperature range	-25...+55°C (continuous)
Short-time service temperature range	-40...+85°C (<16 h) ¹⁾²⁾
Relative humidity	<93%, non-condensing
Atmospheric pressure	86...106 kPa
Altitude	Up to 2000 m
Transport and storage temperature range	-40...+85°C

1) Degradation in MTBF and HMI performance outside the temperature range of -25...+55°C

2) For relays with an LC communication interface, the maximum operating temperature is +70°C

Table 19. Electromagnetic compatibility tests

Description	Type test value	Reference
1 MHz/100 kHz burst disturbance test		IEC 61000-4-18 IEC 60255-26, class III IEEE C37.90.1-2002
<ul style="list-style-type: none"> • Common mode • Differential mode 	2.5 kV 2.5 kV	
3 MHz, 10 MHz and 30 MHz burst disturbance test		IEC 61000-4-18 IEC 60255-26, class III
<ul style="list-style-type: none"> • Common mode 	2.5 kV	
Electrostatic discharge test		IEC 61000-4-2 IEC 60255-26 IEEE C37.90.3-2001
<ul style="list-style-type: none"> • Contact discharge • Air discharge 	8 kV 15 kV	
Radio frequency interference test		IEC 61000-4-6 IEC 60255-26, class III
	10 V (rms) f = 150 kHz...80 MHz	IEC 61000-4-3 IEC 60255-26, class III
	10 V/m (rms) f = 80...2700 MHz	ENV 50204 IEC 60255-26, class III
	10 V/m f = 900 MHz	IEEE C37.90.2-2004
	20 V/m (rms) f = 80...1000 MHz	
Fast transient disturbance test		IEC 61000-4-4 IEC 60255-26 IEEE C37.90.1-2002
<ul style="list-style-type: none"> • All ports 	4 kV	
Surge immunity test		IEC 61000-4-5 IEC 60255-26
<ul style="list-style-type: none"> • Communication • Other ports 	1 kV, line-to-earth 4 kV, line-to-earth 2 kV, line-to-line	
Power frequency (50 Hz) magnetic field immunity test		IEC 61000-4-8
<ul style="list-style-type: none"> • Continuous • 1...3 s 	300 A/m 1000 A/m	
Pulse magnetic field immunity test		IEC 61000-4-9
	1000 A/m 6.4/16 µs	
Damped oscillatory magnetic field immunity test		IEC 61000-4-10
<ul style="list-style-type: none"> • 2 s • 1 MHz 	100 A/m 400 transients/s	
Voltage dips and short interruptions		IEC 61000-4-11
	30%/10 ms 60%/100 ms 60%/1000 ms >95%/5000 ms	

Table 19. Electromagnetic compatibility tests, continued

Description	Type test value	Reference
Power frequency immunity test	Binary inputs only	IEC 61000-4-16 IEC 60255-26, class A
• Common mode	300 V rms	
• Differential mode	150 V rms	
Conducted common mode disturbances	15 Hz...150 kHz Test level 3 (10/1/10 V rms)	IEC 61000-4-16
Emission tests		EN 55011, class A IEC 60255-26 CISPR 11 CISPR 12
• Conducted		
0.15...0.50 MHz	<79 dB (μV) quasi peak <66 dB (μV) average	
0.5...30 MHz	<73 dB (μV) quasi peak <60 dB (μV) average	
• Radiated		
30...230 MHz	<40 dB (μV/m) quasi peak, measured at 10 m distance	
230...1000 MHz	<47 dB (μV/m) quasi peak, measured at 10 m distance	
1...3 GHz	<76 dB (μV/m) peak <56 dB (μV/m) average, measured at 3 m distance	
3...6 GHz	<80 dB (μV/m) peak <60 dB (μV/m) average, measured at 3 m distance	

Table 20. Insulation tests

Description	Type test value	Reference
Dielectric tests	2 kV, 50 Hz, 1 min 500 V, 50 Hz, 1 min, communication	IEC 60255-27
Impulse voltage test	5 kV, 1.2/50 μs, 0.5 J 1 kV, 1.2/50 μs, 0.5 J, communication	IEC 60255-27
Insulation resistance measurements	>100 MΩ, 500 V DC	IEC 60255-27
Protective bonding resistance	<0.1 Ω, 4 A, 60 s	IEC 60255-27

Table 21. Mechanical tests

Description	Requirement	Reference
Vibration tests (sinusoidal)	Class 2	IEC 60068-2-6 (test Fc) IEC 60255-21-1
Shock and bump test	Class 2	IEC 60068-2-27 (test Ea shock) IEC 60068-2-29 (test Eb bump) IEC 60255-21-2
Seismic test	Class 2	IEC 60255-21-3

Table 22. Environmental tests

Description	Type test value	Reference
Dry heat test	<ul style="list-style-type: none"> • 96 h at +55°C • 16 h at +85°C¹⁾ 	IEC 60068-2-2
Dry cold test	<ul style="list-style-type: none"> • 96 h at -25°C • 16 h at -40°C 	IEC 60068-2-1
Damp heat test	<ul style="list-style-type: none"> • 6 cycles (12 h + 12 h) at +25°C...+55°C, humidity >93% 	IEC 60068-2-30
Change of temperature test	<ul style="list-style-type: none"> • 5 cycles (3 h + 3 h) at -25°C...+55°C 	IEC60068-2-14
Storage test	<ul style="list-style-type: none"> • 96 h at -40°C • 96 h at +85°C 	IEC 60068-2-1 IEC 60068-2-2

1) For relays with an LC communication interface the maximum operating temperature is +70°C

Table 23. Product safety

Description	Reference
LV directive	2006/95/EC
Standard	EN 60255-27 (2013) EN 60255-1 (2009)

Table 24. EMC compliance

Description	Reference
EMC directive	2004/108/EC
Standard	EN 60255-26 (2013)

Table 25. RoHS compliance

Description
Complies with RoHS directive 2002/95/EC

Protection functions

Table 26. Three-phase non-directional overcurrent protection (PHxPTOC)

Characteristic	Value			
Operation accuracy	PHLPTOC	Depending on the frequency of the measured current: $f_n \pm 2$ Hz $\pm 1.5\%$ of the set value or $\pm 0.002 \times I_n$		
	PHHPTOC ¹⁾ and PHIPTOC	$\pm 1.5\%$ of set value or $\pm 0.002 \times I_n$ (at currents in the range of $0.1 \dots 10 \times I_n$) $\pm 5.0\%$ of the set value (at currents in the range of $10 \dots 40 \times I_n$)		
Start time ²⁾³⁾	PHIPTOC: $I_{Fault} = 2 \times \text{set Start value}$ $I_{Fault} = 10 \times \text{set Start value}$	Minimum	Typical	Maximum
		16 ms	19 ms	23 ms
	11 ms	12 ms	14 ms	
	PHHPTOC ¹⁾ and PHLPTOC: $I_{Fault} = 2 \times \text{set Start value}$	22 ms	24 ms	25 ms
Reset time	<40 ms			
Reset ratio	Typically 0.96			
Retardation time	<30 ms			
Operate time accuracy in definite time mode	$\pm 1.0\%$ of the set value or ± 20 ms			
Operate time accuracy in inverse time mode	$\pm 5.0\%$ of the theoretical value or ± 20 ms ⁴⁾			
Suppression of harmonics	RMS: No suppression DFT: -50 dB at $f = n \times f_n$, where $n = 2, 3, 4, 5, \dots$ Peak-to-Peak: No suppression P-to-P+backup: No suppression			

1) Not included in REM611

2) Set *Operate delay time* = 0,02 s, *Operate curve type* = IEC definite time, *Measurement mode* = default (depends on stage), current before fault = $0.0 \times I_n$, $f_n = 50$ Hz, fault current in one phase with nominal frequency injected from random phase angle, results based on statistical distribution of 1000 measurements

3) Includes the delay of the signal output contact

4) Includes the delay of the heavy-duty output contact

Table 27. Three-phase non-directional overcurrent protection (PHxPTOC) main settings

Parameter	Function	Value (Range)	Step
Start value	PHLPTOC	$0.05 \dots 5.00 \times I_n$	0.01
	PHHPTOC ¹⁾	$0.10 \dots 40.00 \times I_n$	0.01
	PHIPTOC	$1.00 \dots 40.00 \times I_n$	0.01
Time multiplier	PHLPTOC and PHHPTOC ¹⁾	0.05...15.00	0.01
Operate delay time	PHLPTOC and PHHPTOC ¹⁾	40...200000 ms	10
	PHIPTOC	20...200000 ms	10
Operating curve type ²⁾	PHLPTOC	Definite or inverse time Curve type: 1, 2, 3, 4, 5, 6, 7, 8, 9, 10, 11, 12, 13, 14, 15, 17, 18, 19	
	PHHPTOC ¹⁾	Definite or inverse time Curve type: 1, 3, 5, 9, 10, 12, 15, 17	
	PHIPTOC	Definite time	

1) Not included in this product

2) For further reference, see the Operation characteristics table

Table 28. Non-directional earth-fault protection (EFxPTOC)

Characteristic	Value			
Operation accuracy	EFLPTOC	Depending on the frequency of the measured current: $f_n \pm 2$ Hz $\pm 1.5\%$ of the set value or $\pm 0.002 \times I_n$		
	EFHPTOC and EFIPTOC ¹⁾	$\pm 1.5\%$ of set value or $\pm 0.002 \times I_n$ (at currents in the range of $0.1 \dots 10 \times I_n$) $\pm 5.0\%$ of the set value (at currents in the range of $10 \dots 40 \times I_n$)		
Start time ²⁾³⁾		Minimum	Typical	Maximum
	EFIPTOC ¹⁾ : $I_{Fault} = 2 \times \text{set Start value}$ $I_{Fault} = 10 \times \text{set Start value}$	16 ms 11 ms	19 ms 12 ms	23 ms 14 ms
	EFHPTOC and EFLPTOC: $I_{Fault} = 2 \times \text{set Start value}$	23 ms	26 ms	29 ms
Reset time	Typically 40 ms			
Reset ratio	Typically 0.96			
Retardation time	<30 ms			
Operate time accuracy in definite time mode	$\pm 1.0\%$ of the set value or ± 20 ms			
Operate time accuracy in inverse time mode	$\pm 5.0\%$ of the theoretical value or ± 20 ms ⁴⁾			
Suppression of harmonics	RMS: No suppression DFT: -50 dB at $f = n \times f_n$, where $n = 2, 3, 4, 5, \dots$ Peak-to-Peak: No suppression			

1) Not included in this product

2) *Measurement mode* = default (depends on stage), current before fault = $0.0 \times I_n$, $f_n = 50$ Hz, earth-fault current with nominal frequency injected from random phase angle, results based on statistical distribution of 1000 measurements

3) Includes the delay of the signal output contact

4) Maximum *Start value* = $2.5 \times I_n$, *Start value* multiples in range of 1.5...20

Table 29. Non-directional earth-fault protection (EFxPTOC) main settings

Parameter	Function	Value (Range)	Step
Start value	EFLPTOC	$0.010 \dots 5.000 \times I_n$	0.005
	EFHPTOC	$0.10 \dots 40.00 \times I_n$	0.01
	EFIPTOC ¹⁾	$1.00 \dots 40.00 \times I_n$	0.01
Time multiplier	EFLPTOC and EFHPTOC	0.05...15.00	0.01
Operate delay time	EFLPTOC and EFHPTOC	40...200000 ms	10
	EFIPTOC ¹⁾	20...200000 ms	10
Operating curve type ²⁾	EFLPTOC	Definite or inverse time Curve type: 1, 2, 3, 4, 5, 6, 7, 8, 9, 10, 11, 12, 13, 14, 15, 17, 18, 19	
	EFHPTOC	Definite or inverse time Curve type: 1, 3, 5, 9, 10, 12, 15, 17	
	EFIPTOC ¹⁾	Definite time	

1) Not included in this product

2) For further reference, see the Operation characteristics table

Table 30. Negative-sequence overcurrent protection for machines (MNSPTOC)

Characteristic	Value		
Operation accuracy	Depending on the frequency of the measured current: $f_n \pm 2$ Hz $\pm 1.5\%$ of the set value or $\pm 0.002 \times I_n$		
Start time ¹⁾²⁾	$I_{Fault} = 2.0 \times \text{set Start value}$	Minimum	Typical
		23	25 ms
			Maximum
			28 ms
Reset time	Typically 40 ms		
Reset ratio	Typically 0.96		
Retardation time	<35 ms		
Operate time accuracy in definite time mode	$\pm 1.0\%$ of the set value or ± 20 ms		
Operate time accuracy in inverse time mode	$\pm 5.0\%$ of the theoretical value or ± 20 ms ³⁾		
Suppression of harmonics	DFT: -50 dB at $f = n \times f_n$, where $n = 2, 3, 4, 5, \dots$		

- 1) Negative-sequence current before = 0.0, $f_n = 50$ Hz, results based on statistical distribution of 1000 measurements
- 2) Includes the delay of the signal output contact
- 3) Start value multiples in range of 1.10...5.00

Table 31. Negative-sequence overcurrent protection for machines (MNSPTOC) main settings

Parameter	Function	Value (Range)	Step
Start value	MNSPTOC	$0.01 \dots 0.50 \times I_n$	0.01
Operating curve type	MNSPTOC	ANSI Def. Time IEC Def. Time Inv. Curve A Inv. Curve B	-
Operate delay time	MNSPTOC	100...120000 ms	10
Operation	MNSPTOC	1 = on 5 = off	-
Cooling time	MNSPTOC	5...7200 s	1

Table 32. Loss of load supervision (LOFLPTUC)

Characteristic	Value
Operation accuracy	Depending on the frequency of the measured current: $f_n \pm 2$ Hz $\pm 1.5\%$ of the set value or $\pm 0.002 \times I_n$
Start time	Typically 300 ms
Reset time	Typically 40 ms
Reset ratio	Typically 1.04
Retardation time	<35 ms
Operate time accuracy in definite time mode	$\pm 1.0\%$ of the set value or ± 20 ms

Table 33. Loss of load supervision (LOFLPTUC) main settings

Parameter	Function	Value (Range)	Step
Start value low	LOFLPTUC	$0.01 \dots 0.50 \times I_n$	0.01
Start value high	LOFLPTUC	$0.01 \dots 1.00 \times I_n$	0.01
Operate delay time	LOFLPTUC	400...600000 ms	10
Operation	LOFLPTUC	1 = on 5 = off	-

Table 34. Motor load jam protection (JAMPTOC)

Characteristic	Value
Operation accuracy	Depending on the frequency of the measured current: $f_n \pm 2$ Hz $\pm 1.5\%$ of the set value or $\pm 0.002 \times I_n$
Reset time	Typically 40 ms
Reset ratio	Typically 0.96
Retardation time	<35 ms
Operate time accuracy in definite time mode	$\pm 1.0\%$ of the set value or ± 20 ms

Table 35. Motor load jam protection (JAMPTOC) main settings

Parameter	Function	Value (Range)	Step
Operation	JAMPTOC	1 = on 5 = off	-
Start value	JAMPTOC	$0.10 \dots 10.00 \times I_n$	0.01
Operate delay time	JAMPTOC	100...120000 ms	10

Table 36. Motor start-up supervision (STTPMSU)

Characteristic	Value						
Operation accuracy	Depending on the frequency of the measured current: $f_n \pm 2$ Hz $\pm 1.5\%$ of the set value or $\pm 0.002 \times I_n$						
Start time ¹⁾²⁾	<table border="1"> <thead> <tr> <th>Minimum</th> <th>Typical</th> <th>Maximum</th> </tr> </thead> <tbody> <tr> <td>27 ms</td> <td>30 ms</td> <td>34 ms</td> </tr> </tbody> </table> $I_{Fault} = 1.1 \times \text{set } Start \text{ detection } A$	Minimum	Typical	Maximum	27 ms	30 ms	34 ms
Minimum	Typical	Maximum					
27 ms	30 ms	34 ms					
Operate time accuracy	$\pm 1.0\%$ of the set value or ± 20 ms						
Reset ratio	Typically 0.90						

1) Current before = $0.0 \times I_n$, $f_n = 50$ Hz, overcurrent in one phase, results based on statistical distribution of 1000 measurements

2) Includes the delay of the signal output contact

Table 37. Motor start-up supervision (STTPMSU) main settings

Parameter	Function	Value (Range)	Step
Motor start-up A	STTPMSU	1.0...10.0 × I _n	0.1
Motor start-up time	STTPMSU	1..80 s	1
Lock rotor time	STTPMSU	2...120 s	1
Operation	STTPMSU	1 = on 5 = off	-
Operation mode	STTPMSU	1 = Ilt 2 = Ilt, CB 3 = Ilt + stall 4 = Ilt + stall, CB	-
Restart inhibit time	STTPMSU	0...250 min	1

Table 38. Phase reversal protection (PREVPTOC)

Characteristic	Value		
Operation accuracy	Depending on the frequency of the measured current: f _n ±2 Hz ±1.5% of the set value or ±0.002 × I _n		
Start time ¹⁾²⁾	Minimum	Typical	Maximum
	23 ms	25 ms	28 ms
	I _{Fault} = 2.0 × set <i>Start value</i>		
Reset time	Typically 40 ms		
Reset ratio	Typically 0.96		
Retardation time	<35 ms		
Operate time accuracy in definite time mode	±1.0% of the set value or ±20 ms		
Suppression of harmonics	DFT: -50 dB at f = n × f _n , where n = 2, 3, 4, 5,...		

1) Negative-sequence current before = 0.0, f_n = 50 Hz, results based on statistical distribution of 1000 measurements

2) Includes the delay of the signal output contact

Table 39. Phase reversal protection (PREVPTOC) main settings

Parameter	Function	Value (Range)	Step
Start value	PREVPTOC	0.05...1.00 × I _n	0.01
Operate delay time	PREVPTOC	100...60000 ms	10
Operation	PREVPTOC	1 = on 5 = off	-

Table 40. Thermal overload protection for motors (MPTTR)

Characteristic	Value
Operation accuracy	Depending on the frequency of the measured current: f _n ±2 Hz Current measurement: ±1.5% of the set value or ±0.002 × I _n (at currents in the range of 0.01...4.00 × I _n)
Operate time accuracy ¹⁾	±2.0% of the theoretical value or ±0.50 s

1) Overload current > 1.2 × Operate level temperature

Table 41. Thermal overload protection for motors (MPTTR) main settings

Parameter	Function	Value (Range)	Step
Overload factor	MPTTR	1.00...1.20	0.01
Alarm thermal value	MPTTR	50.0...100.0%	0.1
Restart thermal Val	MPTTR	20.0...80.0%	0.1
Weighting factor p	MPTTR	20.0...100.0%	0.1
Time constant normal	MPTTR	80...4000 s	1
Time constant start	MPTTR	80...4000 s	1
Env temperature mode	MPTTR	1 = FLC Only 2 = Use input 3 = Set Amb Temp	-
Env temperature Set	MPTTR	-20.0...70.0°C	0.1
Operation	MPTTR	1 = on 5 = off	-

Table 42. Circuit breaker failure protection (CCBRBRF)

Characteristic	Value
Operation accuracy	Depending on the frequency of the measured current: $f_n \pm 2$ Hz $\pm 1.5\%$ of the set value or $\pm 0.002 \times I_n$
Operate time accuracy	$\pm 1.0\%$ of the set value or ± 20 ms
Reset time ¹⁾	Typically 40 ms
Retardation time	<20 ms

1) Trip pulse time defines the minimum pulse length

Table 43. Circuit breaker failure protection (CCBRBRF) main settings

Parameter	Function	Value (Range)	Step
Current value	CCBRBRF	$0.05...2.00 \times I_n$	0.05
Current value Res	CCBRBRF	$0.05...2.00 \times I_n$	0.05
CB failure mode	CCBRBRF	1 = Current 2 = Breaker status 3 = Both	-
CB fail retrip mode	CCBRBRF	1 = Off 2 = Without check 3 = Current check	-
Retrip time	CCBRBRF	0...60000 ms	10
CB failure delay	CCBRBRF	0...60000 ms	10
CB fault delay	CCBRBRF	0...60000 ms	10

Control functions

Table 44. Emergency start-up (ESMGAPC)

Characteristic	Value
Operation accuracy	At the frequency $f = f_n$ $\pm 1.5\%$ of the set value or $\pm 0.002 \times U_n$

Table 45. Emergency start-up (ESMGAPC) main settings

Parameter	Function	Value (Range)	Step
Motor stand still A	ESMGAPC	$0.05 \dots 0.20 \times I_n$	0.01
Operation	ESMGAPC	1 = on 5 = off	-

Condition monitoring and supervision functions

Table 46. Runtime counter for machines and devices (MDSOPT)

Description	Value
Motor runtime measurement accuracy ¹⁾	±0.5%

1) Of the reading, for a stand-alone relay, without time synchronization

Measurement functions

Table 47. Three-phase current measurement (CMMXU)

Characteristic	Value
Operation accuracy	Depending on the frequency of the measured current: $f_n \pm 2$ Hz $\pm 0.5\%$ or $\pm 0.002 \times I_n$ (at currents in the range of $0.01 \dots 4.00 \times I_n$)
Suppression of harmonics	DFT: -50 dB at $f = n \times f_n$, where $n = 2, 3, 4, 5, \dots$ RMS: No suppression

Table 48. Sequence current measurement (CSMSQI)

Characteristic	Value
Operation accuracy	Depending on the frequency of the measured current: $f/f_n = \pm 2$ Hz $\pm 1.0\%$ or $\pm 0.002 \times I_n$ at currents in the range of $0.01 \dots 4.00 \times I_n$
Suppression of harmonics	DFT: -50 dB at $f = n \times f_n$, where $n = 2, 3, 4, 5, \dots$

Table 49. Residual current measurement (RESCMMXU)

Characteristic	Value
Operation accuracy	At the frequency $f = f_n$ $\pm 0.5\%$ or $\pm 0.002 \times I_n$ (at currents in the range of $0.01 \dots 4.00 \times I_n$)
Suppression of harmonics	DFT: -50 dB at $f = n \times f_n$, where $n = 2, 3, 4, 5, \dots$ RMS: No suppression

17. Local HMI

The relay is equipped with a four-line liquid crystal display. Depending on the chosen font and language, the number of visible lines may vary. The display is designed for entering parameter settings of the protection and control functions. It is also suited for remotely controlled substations where the relay is only occasionally accessed locally via the front panel user interface.

The display offers front-panel user interface functionality with menu navigation and menu views. Depending on the configuration, the relay displays the related measuring values.

The local HMI includes a push button (L/R) for local/remote operation of the relay. When the relay is in the local mode, it can be operated only by using the local front-panel user interface. When the relay is in the remote mode, it can execute commands sent from a remote location. The relay supports the remote selection of the local/remote mode via a binary input. This feature facilitates, for example, the use of an external switch at the substation to ensure that all relays are in the local mode during maintenance work and that the circuit breakers cannot be operated remotely from the network control center.

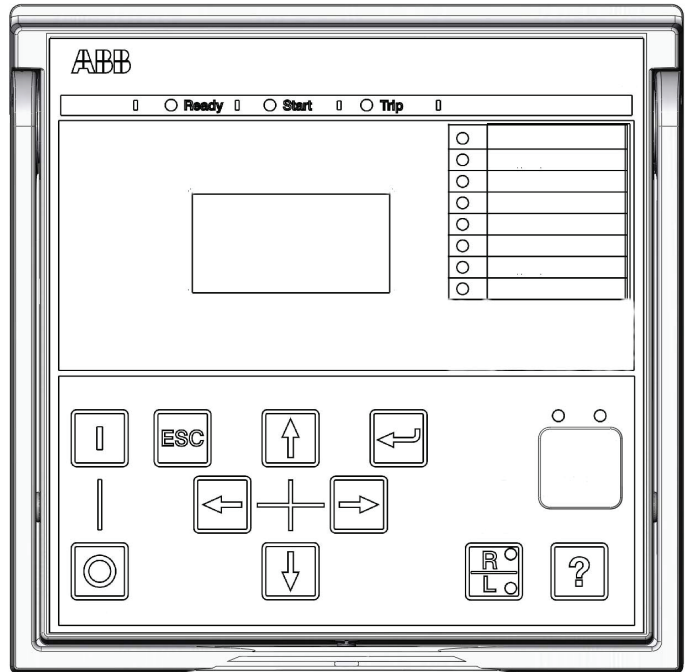

Figure 7. Front panel of 611 series relays

Table 50. Small display

Character size ¹⁾	Rows in the view	Characters per row
Small, mono-spaced (6 × 12 pixels)	5	20
Large, variable width (13 × 14 pixels)	3	8 or more

1) Depending on the selected language

18. Mounting methods

By means of appropriate mounting accessories, the standard relay case can be flush mounted, semi-flush mounted or wall mounted. The flush mounted and wall mounted relay cases can also be mounted in a tilted position (25°) using special accessories.

Further, the relays can be mounted in any standard 19" instrument cabinet by means of 19" mounting panels available with cut-outs for one or two relays. Alternatively, the relays can be mounted in 19" instrument cabinets by means of 4U Combiflex equipment frames.

For routine testing purposes, the relay cases can be equipped with test switches, type RTXP 18, which can be mounted side by side with the relay cases.

Mounting methods

- Flush mounting
- Semi-flush mounting
- Semi-flush mounting in a 25° tilt
- Rack mounting
- Wall mounting
- Mounting to a 19" equipment frame
- Mounting with an RTXP 18 test switch to a 19" rack

Panel cut-out for flush mounting

- Height: 161.5 ±1 mm
- Width: 165.5 ±1 mm

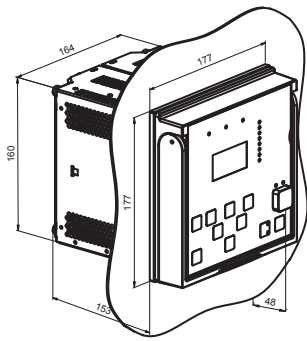

Figure 8. Flush mounting

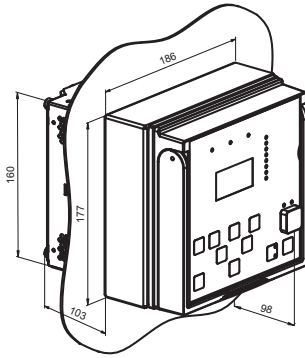

Figure 9. Semi-flush mounting

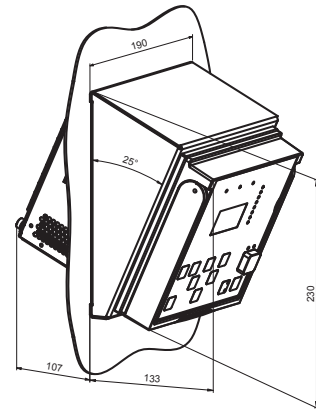

Figure 10. Semi-flush mounting in a 25° tilt

19. Relay case and plug-in unit

The relay cases are assigned to a certain type of plug-in unit. For safety reasons, the relay cases for current measuring relays are provided with automatically operating contacts for short-circuiting the CT secondary circuits when a relay unit is withdrawn from its case. The relay case is further provided with a mechanical coding system preventing the current measuring relay units from being inserted into relay cases intended for voltage measuring relay units.

REM611

Product version: 2.0

20. Selection and ordering data

The relay type and serial number label identifies the protection relay. The label is placed above the local HMI on the upper part of the plug-in-unit. An order code label is placed on the side of the plug-in unit as well as inside the case. The order code consists of a string of letters and digits generated from the relay's hardware and software modules.

[Product Selection Tool](#) (PST), a Next-Generation Order Number Tool, supports order code creation for ABB Distribution Automation IEC products with emphasis on, but not exclusively for, the Relion product family. PST is an easy-to-use, online tool always containing the latest product information. The complete order code can be created with detailed specification and the result can be printed and mailed. Registration is required.

Use [ABB Library](#) to access the selection and ordering information and to generate the order number.

#	Description	
1-2 Product Series, Size, Plug-in		
	Relay	RE
3 Main application		
	Motor protection and control	M
4-6 IED series		
	611 series	611
7 IED case, plugin unit, test switch		
	Complete relay	H
	Complete Relay with test switch installed and wired in 19" cover plate	K
	Complete Relay with test switch installed and wired for CombiFlex rack mounting	L
8 Standard		
	IEC	B
	CN	C

REM611HBAAAA1NN11G

#	Description	
9 Standard configuration / Analog Inputs		
10		
	Motor protection [4I + 4BI (Io 1/5A)]	AA
	Motor protection [4I + 4BI (Io 0.2/1A)]	AB
11 Communication module		
	Ethernet 100Base FX (LC)	A
	Ethernet 100Base TX (RJ45)	B
	RS485 (including IRIG-B)	C
	Ethernet 100Base TX (3xRJ45) with HSR/PRP	D
	None	N
12 Communication (Protocol)		
	IEC 61850	A
	Modbus	B
	IEC 61850+Modbus	C
13 Language		
	English	1
	English and Chinese	2

REM611HBAAAA1NN11G

REM611

Product version: 2.0

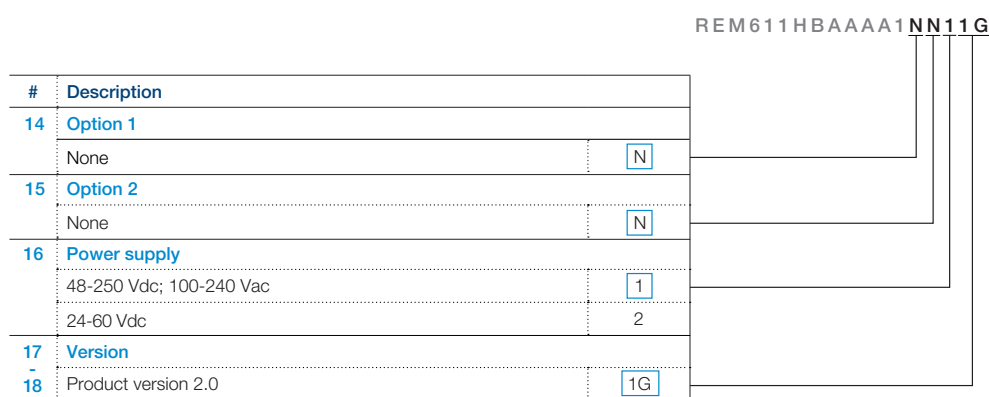

Example code: **R E M 6 1 1 H B A A A A 1 N N 1 1 G**

Your ordering code:

Digit (#)	1	2	3	4	5	6	7	8	9	10	11	12	13	14	15	16	17	18
Code	<input type="text"/>	<input type="text"/>	<input type="text"/>	<input type="text"/>	<input type="text"/>	<input type="text"/>	<input type="text"/>	<input type="text"/>	<input type="text"/>	<input type="text"/>	<input type="text"/>	<input type="text"/>	<input type="text"/>	<input type="text"/>	<input type="text"/>	<input type="text"/>	<input type="text"/>	<input type="text"/>

Figure 11. Ordering key for complete relays

21. Accessories and ordering data

Table 51. Mounting accessories

Item	Order number
Semi-flush mounting kit	1MRS050696
Wall mounting kit	1MRS050697
Inclined semi-flush mounting kit	1MRS050831
19" rack mounting kit with cut-out for one relay	1MRS050694
19" rack mounting kit with cut-out for two relays	1MRS050695
Mounting bracket for one relay with test switch RTXP in 4U Combiflex (RHGT 19" variant C)	2RCA022642P0001
Mounting bracket for one relay in 4U Combiflex (RHGT 19" variant C)	2RCA022643P0001
19" rack mounting kit for one relay and one RTXP18 test switch (the test switch is not included in the delivery)	2RCA021952A0003
19" rack mounting kit for one relay and one RTXP24 test switch (the test switch is not included in the delivery)	2RCA022561A0003

22. Tools

The protection relay is delivered as a preconfigured unit. The default parameter setting values can be changed from the front-panel user interface (local HMI), the Web browser-based user interface (Web HMI) or Protection and Control IED Manager PCM600 in combination with the relay-specific connectivity package.

PCM600 offers extensive relay configuration functions. For example, depending on the protection relay, the relay signals, application, graphical display and single-line diagram, and IEC 61850 communication, including horizontal GOOSE communication, can be modified with PCM600.

When the Web HMI is used, the protection relay can be accessed either locally or remotely using a Web browser (Internet Explorer). For security reasons, the Web HMI is

REM611

Product version: 2.0

enabled by default but it can be enabled via the local HMI. The Web HMI functionality can be limited to read-only access.

The relay connectivity package is a collection of software and specific relay information, which enables system products and tools to connect and interact with the protection relay. The connectivity packages reduce the risk of errors in system

integration, minimizing device configuration and setup times. Further, the connectivity packages for protection relays of this product series include a flexible update tool for adding one additional local HMI language to the protection relay. The update tool is activated using PCM600, and it enables multiple updates of the additional HMI language, thus offering flexible means for possible future language updates.

Table 52. Tools

Description	Version
PCM600	2.7 or later
Web browser	IE 8.0, IE 9.0, IE 10.0 or IE 11.0
REM611 Connectivity Package	2.0 or later

Table 53. Supported functions

Function	Web HMI	PCM600
Relay parameter setting	●	●
Saving of relay parameter settings in the relay	●	●
Signal monitoring	●	●
Disturbance recorder handling	●	●
Alarm LED viewing	●	●
Access control management	●	●
Relay signal configuration	● ¹⁾	● ²⁾
Modbus® communication configuration (communication management)	-	●
Saving of relay parameter settings in the tool	-	●
Disturbance record analysis	-	●
XRIO parameter export/import	●	●
IEC 61850 communication configuration, GOOSE (communication configuration)	-	●
Phasor diagram viewing	●	-
Event viewing	●	●
Saving of event data on the user's PC	●	●
Online monitoring	-	●

● = Supported

1) Relay input/output signal configuration

2) For horizontal GOOSE signals only

23. Cyber security

The relay supports role based user authentication and authorization. It can store 2048 audit trail events to a nonvolatile memory. The nonvolatile memory is based on a memory type which does not need battery backup or regular component exchange to maintain the memory storage. FTP and Web HMI

use TLS encryption with a minimum of 128 bit key length protecting the data in transit. In this case the used communication protocols are FTPS and HTTPS. All rear communication ports and optional protocol services can be deactivated according to the required system setup.

24. Terminal diagram

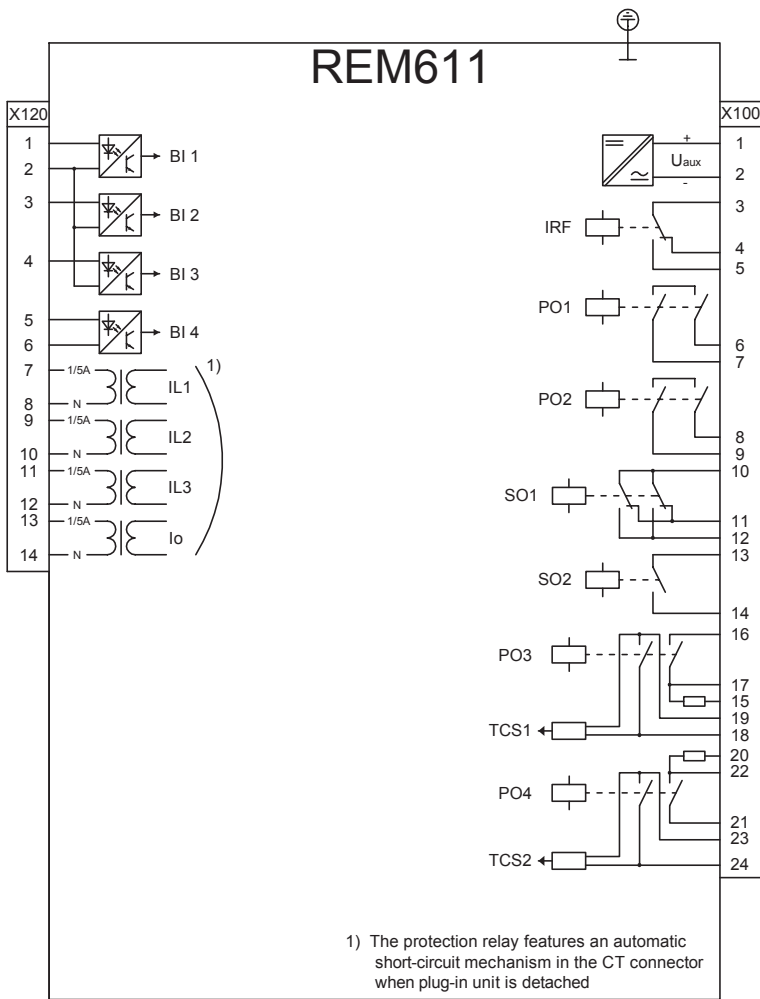

Figure 12. Terminal diagram of configuration A

25. Certificates

DNV GL has issued an IEC 61850 Edition 2 Certificate Level A1 for Relion® 611 series. Certificate number: 10010221-OPE/INC 15-2723.

DNV GL has issued an IEC 61850 Edition 1 Certificate Level A1 for Relion® 611Y5 series. Certificate number: 10010221-OPE/INC 15-2736.

Additional certificates can be found on the [product page](#).

26. References

The www.abb.com/substationautomation portal provides information on the entire range of distribution automation products and services.

The latest relevant information on the REM611 protection relay is found on the [product page](#). Scroll down the page to find and download the related documentation.

27. Functions, codes and symbols

Table 54. Functions included in the relay

Function	IEC 61850	IEC 60617	IEC-ANSI
Protection			
Three-phase non-directional overcurrent protection, low stage, instance 1	PHLPTOC1	3I> (1)	51P-1 (1)
Three-phase non-directional overcurrent protection, instantaneous stage, instance 1	PHIPTOC1	3I>>> (1)	50P/51P (1)
Non-directional earth-fault protection, low stage, instance 1	EFLPTOC1	Io> (1)	51N-1 (1)
Non-directional earth-fault protection, high stage, instance 1	EFHPTOC1	Io>> (1)	51N-2 (1)
Negative-sequence overcurrent protection for machines, instance 1	MNSPTOC1	I2>M (1)	46M (1)
Negative-sequence overcurrent protection for machines, instance 2	MNSPTOC2	I2>M (2)	46M (2)
Loss of load supervision	LOFLPTUC1	3I<	37
Motor load jam protection	JAMPTOC1	Ist>	51LR
Motor start-up supervision	STTPMSU1	Is2t n<	49,66,48,51LR
Phase reversal protection	PREVPTOC1	I2>>	46R
Thermal overload protection for motors	MPTR1	3Ith>M	49M
Circuit breaker failure protection	CCBRBF1	3I>/Io>BF	51BF/51NBF
Master trip, instance 1	TRPPTRC1	Master Trip (1)	94/86 (1)
Other			
Input switch group ¹⁾	ISWGAPC	ISWGAPC	ISWGAPC
Output switch group ²⁾	OSWGAPC	OSWGAPC	OSWGAPC
Selector ³⁾	SELGAPC	SELGAPC	SELGAPC
Minimum pulse timer (2 pcs) ⁴⁾	TPGAPC	TP	TP
Minimum pulse timer (2 pcs, second resolution), instance 1	TPSGAPC	TPS (1)	TPS (1)
Move (8 pcs), instance 1	MVGAPC	MV (1)	MV (1)
Control			
Circuit-breaker control	CBXCBR1	I <-> O CB	I <-> O CB
Emergency start-up	ESMGAPC1	ESTART	ESTART
Condition monitoring and supervision			
Trip circuit supervision, instance 1	TCSSCBR1	TCS (1)	TCM (1)
Trip circuit supervision, instance 2	TCSSCBR2	TCS (2)	TCM (2)
Runtime counter for machines and devices	MDSOPT1	OPTS	OPTM
Logging			
Disturbance recorder	RDRE1	DR (1)	DFR(1)
Fault recorder	FLTRFRC1	-	FR
Measurement			

REM611

Product version: 2.0

Table 54. Functions included in the relay, continued

Function	IEC 61850	IEC 60617	IEC-ANSI
Three-phase current measurement, instance 1	CMMXU1	3I	3I
Sequence current measurement	CSMSQ11	I1, I2, I0	I1, I2, I0
Residual current measurement, instance 1	RESCMMXU1	Io	In

1) 10 instances

2) 20 instances

3) 6 instances

4) 10 instances

28. Document revision history

Document revision/date	Product version	History
A/2011-11-18	1.0	First release
B/2012-05-04	1.0	Content updated
C/2012-05-23	1.0	Content updated
D/2014-06-17	1.0	Content updated
E/2016-02-22	2.0	Content updated to correspond to the product version
F/2017-10-31	2.0	Content updated
G/2019-04-10	2.0	Content updated



ABB Distribution Solutions
Distribution Automation

P.O. Box 699

FI-65101 VAASA, Finland

Phone +358 10 22 11

www.abb.com/mediumvoltage

www.abb.com/relion